

SS119 Series Housings

316L Stainless Steel
Pressure, 700 Bar
Ports, 1/8" or 1/4"
Element, 12.32.□

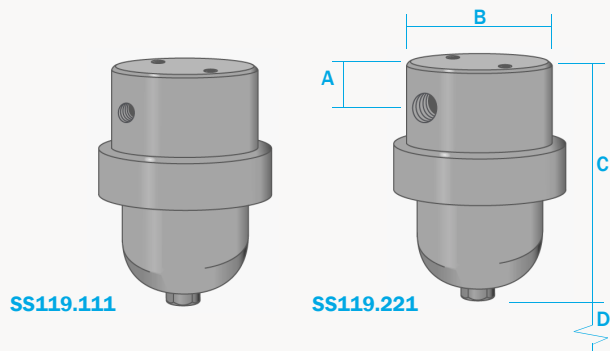

The SS119 series filter housings are specified for 1/8" & 1/4" line size applications up to 700 Bar where response times are critical. If the flow rate or contamination is higher, or where service intervals must be kept as long as possible, the SS129 series housings should be considered. For applications less than 340 Bar see the SS117 series housings.

Standard housings have NPT ports and include Viton gaskets. Other gaskets types are available as an option. BSPT and BSPP port types are also available.

The housings are free from welds and comply with NACE MR-01-75.

Principal Specifications

Housing Model	SS119.101	SS119.111	SS119.201	SS119.221
Port Size - NPT	1/8"	1/8"	1/4"	1/4"
Drain - NPT	None	1/8"	None	1/4"
Maximum Pressure - Bar (1)	700	700	700	700
Maximum Temperature - °C (2)	200	200	200	200
Materials of Construction (3)				
Head, Bowl & Internals	316L	316L	316L	316L
Gaskets	Viton	Viton	Viton	Viton
Principal Dimensions				
A - mm	22	22	22	22
B - mm	65	65	65	65
C - mm	109	109	109	109
D - mm	40	40	40	40
Volume - cc	26	26	26	26
Weight - kg	1.6	1.6	1.6	1.6
Accessories				
Standard Gasket Set	GVSS119	GVSS119	GVSS119	GVSS119
PTFE Gasket Set	GTSS119	GTSS119	GTSS119	GTSS119
High Temperature Gasket	GHSS119	GHSS119	GHSS119	GHSS119
Kalrez Gasket Set	GKSS119	GKSS119	GKSS119	GKSS119
Nitrile Gasket Set	GNSS119	GNSS119	GNSS119	GNSS119
EPDM Gasket Set	GESS119	GESS119	GESS119	GESS119
Support Core	SCSS11	SCSS11	SCSS11	SCSS11
Mounting Bracket	MBSS21	MBSS21	MBSS21	MBSS21
Filter Element Code (4)	12.32.□	12.32.□	12.32.□	12.32.□

- Notes**
- (1) Above 200°C the pressure rating is reduced, consult us for the exact rating at any specific temperature.
 - (2) Maximum temperature 200°C using standard seals. For up to 450°C use a high temperature gasket.
 - (3) Material abbreviations - 316L = 316L Stainless Steel, PTFE = Polytetrafluoroethylene, EPDM = Ethylene-Propylene
 - (4) Replace the □ with the grade required, e.g. 12.32.5CK, 12.32.S25V, 12.32.T20