

SM215 Series Housings

316L Stainless Steel
Pressure, 100 Bar
Ports, 1/4 & 1/2"
Element, 25.64.□
Membrane, MT.61.□

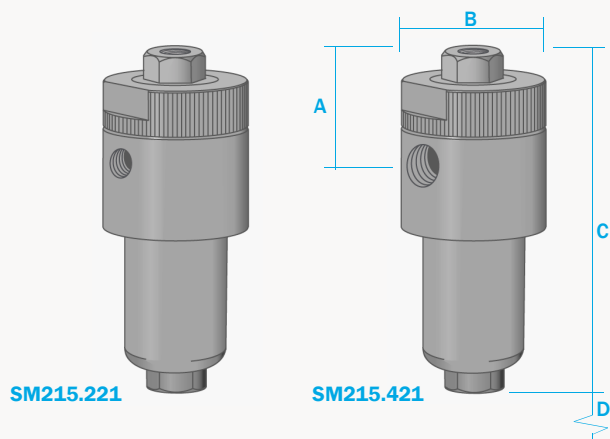

The SM215 combination housings have both a coalescing filter element and a large diameter PTFE membrane in a single unit. The porous PTFE membrane is supported by a sintered porous stainless steel disc on the outlet side. The wet sample gas enters through the inlet port and through the coalescing element to remove the bulk of the liquid and then to the membrane. Because the membrane will only allow molecules of gas or vapour to pass through to the outlet all remaining liquid is stopped. Any liquid in the sample will flow to the drain port. This port can also be used as a bypass function for the main flow. Two grades of PTFE membrane are available and more information can be found in the data sheets CF/1.2/051 and CF/1.2/052.

Standard housings have NPT ports and include Viton gaskets. Other gaskets types are available as an option. BSPT and BSPP port types are also available.

The housings are free from welds and comply with NACE MR-01-75.

Principal Specifications

Housing Model	SM215.221	SM215.421
Port Size - NPT	1/4"	1/2"
Drain - NPT	1/4"	1/4"
Maximum Pressure - Bar	100	100
Maximum Temperature - °C	100	100
Materials of Construction (1)		
Head, Bowl & Internals	316L	316L
Gaskets	Viton	Viton
Principal Dimensions		
A - mm	47	47
B - mm	75	75
C - mm	160	160
D - mm	75	75
Volume - cc	110	110
Weight - kg	1.5	1.5
Accessories		
Standard Gasket Set	GVSM215	GVSM215
PTFE Gasket Set	GTSM215	GTSM215
Kalrez Gasket Set	GKSM215	GKSM215
Nitrile Gasket Set	GNSM215	GNSM215
EPDM Gasket Set	GESM125	GESM215
Membrane Code (2)	MT.61.□	MT.61.□
Element Code (3)	25.64.□	25.64.□

Notes (1) Material abbreviations - 316L = 316L Stainless Steel, PTFE = Polytetrafluoroethene, EPDM = Ethylene-Propylene

(2) Replace the □ with the grade required, e.g. MT.61.M1 or MT.61.M2

(3) Replace the □ with the grade required, e.g. 25.64.5CK or 25.64.5CK